

CENTRIFUGAL BLOWERS AND EXHAUSTERS



CONTINENTAL INDUSTRIE S.A.S

PRESENTATION OF A LEADING COMPANY

More than 30 years of experience in research, development and manufacture of centrifugal machines with several thousand machines installed, make CONTINENTAL INDUSTRIE blowers and exhausters the symbol of reliability and confidence for continuous duty and extremely rugged service, 24 hours a day, 7 days a week.

EUROPEAN DYNAMISM

Our factory located in the Ain department, thirty kilometers from Lyon, benefits from its exceptional location in the center of Europe.

Over the years CONTINENTAL INDUSTRIE has set up an experienced and dynamic team and created a structure bringing together engineers, technicians and salesmen. The sole objective : to provide industry with the best equipment for the problem of air gas movement.

A NEW GENERATION

In the last few years, our engineering office, in association with two French research centers specialized in fluid mechanics, has done everything to optimize the efficiency of our machines and offer you a new generation of centrifugal boosters and exhausters.

As a result, CONTINENTAL INDUSTRY now offers a new high efficiency generation from 100 to 70 000 m³/h of a dry, clean, non pulsing air to pressures attaining 1,8 bar and vacuums up to 6 700 mm H₂O (WG).

A SIMPLE AND PRECISE DESIGN

The extremely simple design of our machines guarantees maximum safety, which is absolutely necessary in all fields of industry in which production depends on the distribution of clean and dry air at a constant pressure.

Cast aluminium parts, precision machining to fine tolerances, absence of mechanical and wearing parts in contact enable our machines to operate in extremely safe conditions, practically without vibration, and with a very low sound level meeting European and American standards.



CONTINENTAL INDUSTRIE S.A.S

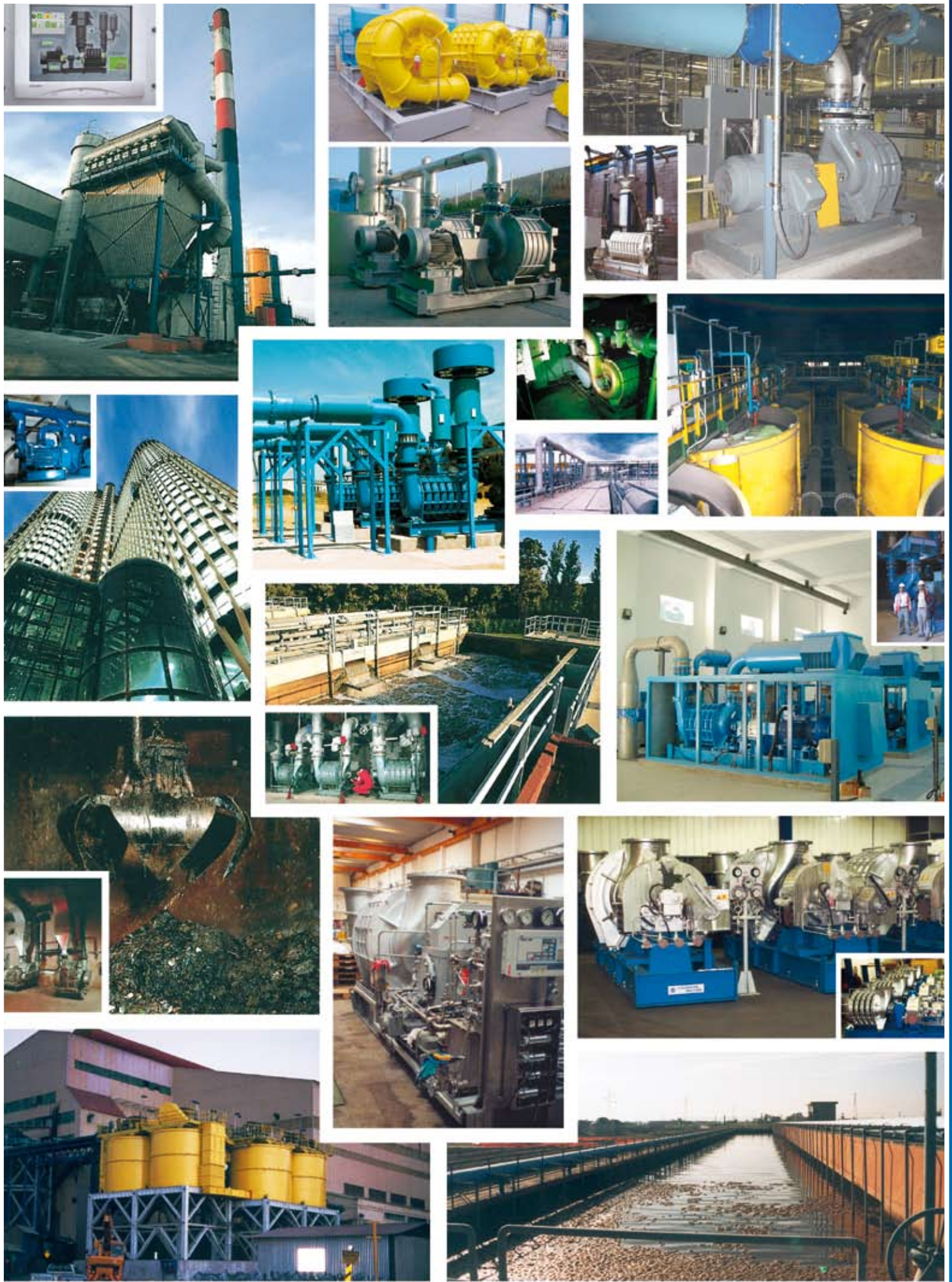

CONSTRUCTION

CASING

Depending on the model, the inlet and outlet heads and intermediate sections are made of either cast iron or aluminium. In order to suit the pressure requirements, it is possible to vary the number of stages with a maximum of 10 on the small machines and 7 on the larger ones. The heads and intermediate sections are spigotted to each other and clamped together by steel tie-rods. The inlet and outlet connections are normally mounted vertically, but if required may be oriented differently. Sealing between the components is ensured by the use of a compound sealant or, in certain cases, by "O" rings.

IMPELLER ASSEMBLY

The impellers are cast in treated aluminium alloy, and for certain applications are fabricated by riveting. All impellers are statically balanced, then keyed to a ground carbon steel shaft. The complete rotor assembly is then dynamically balanced so as to ensure a minimum vibration amplitude of 30 MIC when running. Different types of impeller are available, i.e. radial or curved, which enables us to meet a wider variety of duties.

BEARING HOUSINGS

The bearings are mounted in independent cast iron housings. These housings are securely bolted to the inlet and outlet heads, and allow easy access for routine maintenance. The bearings are the only running contacts between the shaft and casing. Sealing of the housing is by graphitized straps, or on the larger machines by segmented carbon rings, which are held together by a stainless steel spring. Leakage is thus reduced to a minimum with this type of seal. In the case of aggressive gases, sealing is by the use of double mechanical seals. The bearings are lubricated either using grease for machines up to 5000 m³/h or by oil replenishment by a constant level oiler for the larger machines.

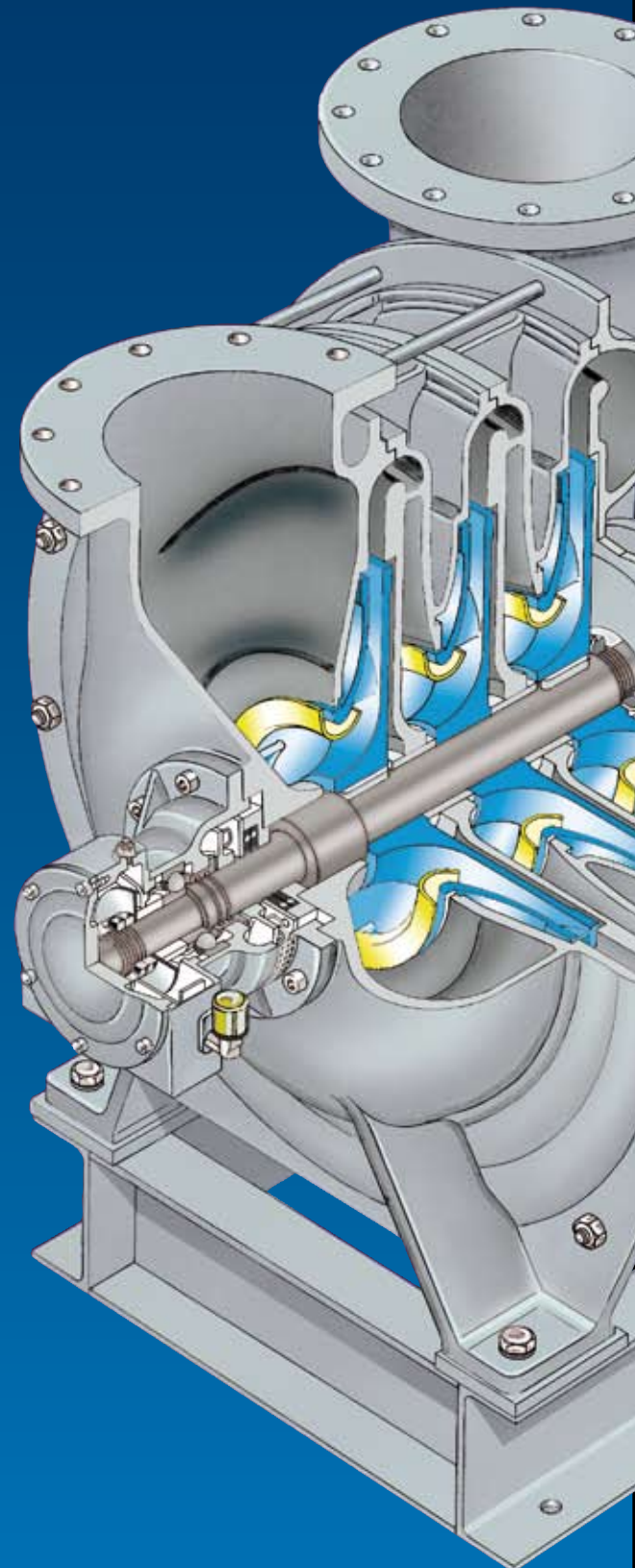

AND ADVANTAGES

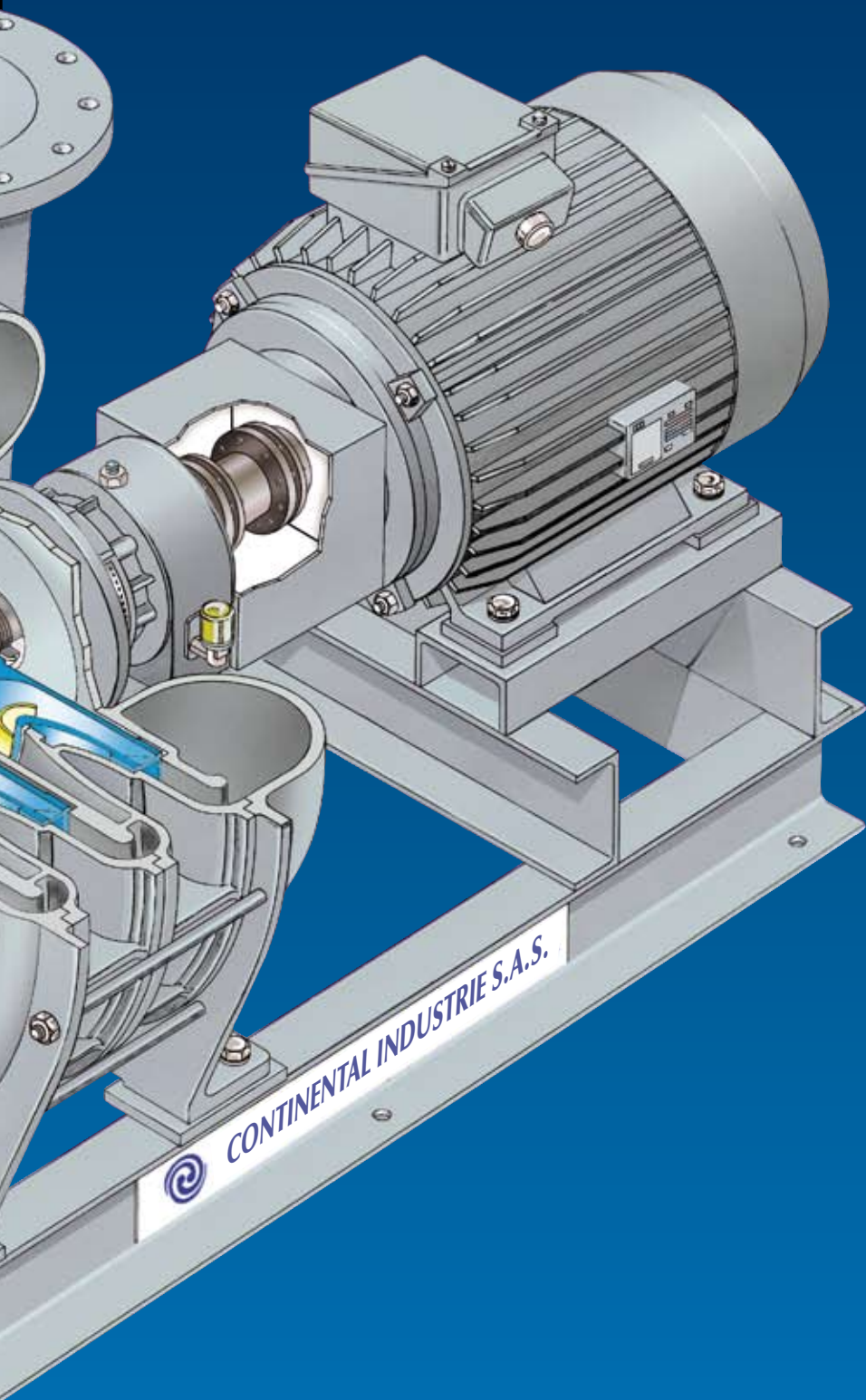

CONTINENTAL INDUSTRIE S.A.S.

THE MARKETS WE SERVE

- Carbon black production
- Sulfur recovery
- Furnaces in smelters & refineries
- Waste water treatment aeration
- Electroplating tank solution agitation
- Sugar conditioning
- Glass tempering
- Fluidizing
- Asphalt oxidation
- Fermentation process
- Filter cake dewatering
- Pneumatic conveying
- Drying of metal & non metal strips
- Air Knives
- LNG plants
- Asbestos dust removal
- Paper dust pick up and slitter knives
- Zinc coating
- Clean and super clean rooms
- Central vacuum cleaning system for over 100 applications
- Paper dewatering
- Textile and carpet dewatering
- Cooling and heating
- Supercharging
- Gas boosting
- Process air
- Air purging
- Quenching
- Air curtains
- Air cushions
- Air sampling
- Metal and plastic extrusion
- Fish ponds and aquaculture tanks aeration
- Exhaust and corrosive fumes removal
- Bio-gas recovery
- Methan removal/soil clean up
- Digester gas
- Combustion processes
- Military aircraft ground support equipment
- Vacuum holding
- Steam removal
- Flotation
- Etc...



APPLICATIONS

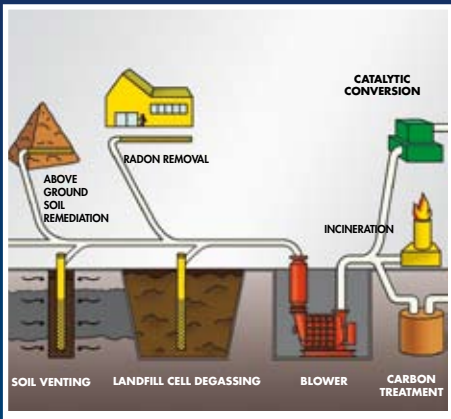

Landfill gas handling

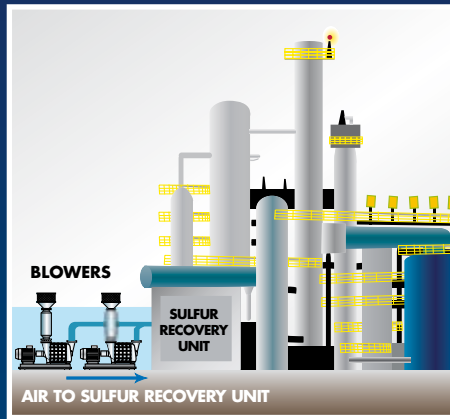

Sulfur recovery

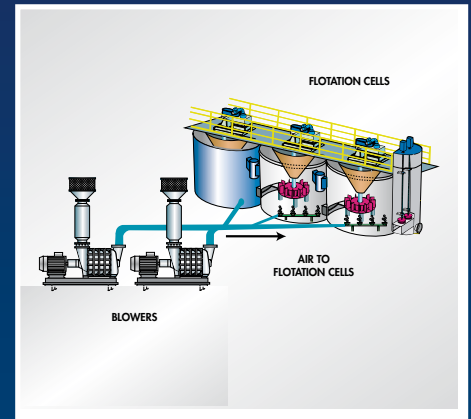

Flotation

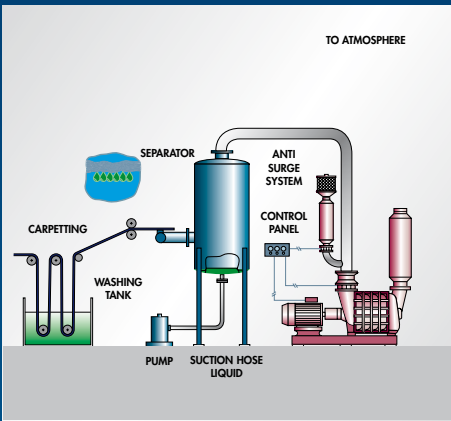

Vacuum extraction of liquid

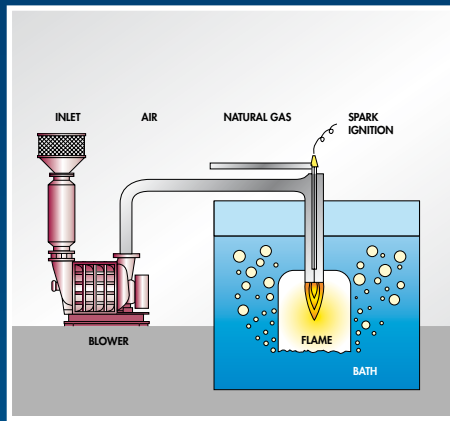

Submerged combustion burner

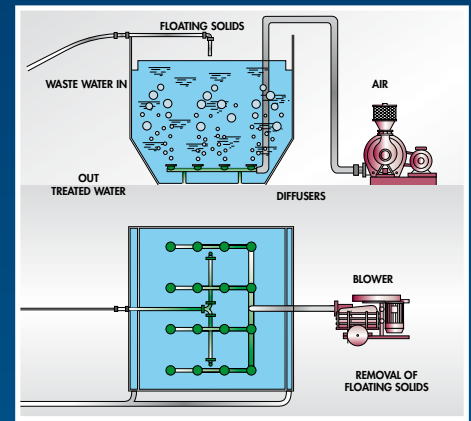

Water treatment (aeration)



Exhauster for centralized vacuum cleaning systems

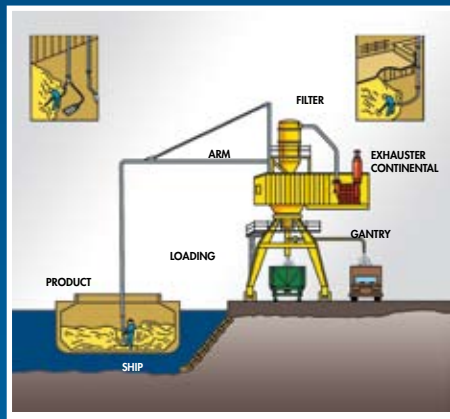

Vacuum conveying

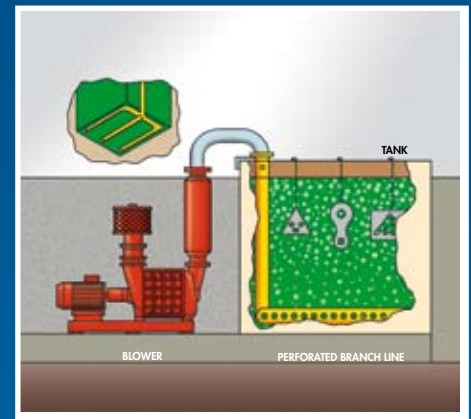

Electroplating tank agitation

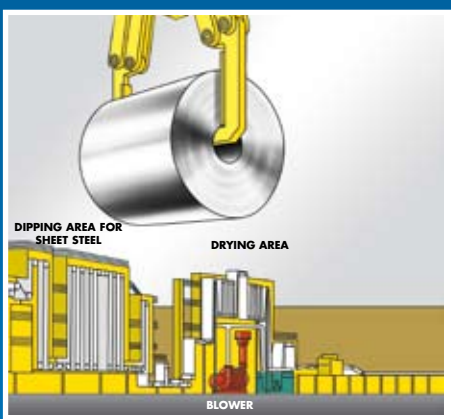

High velocity air knife dryers

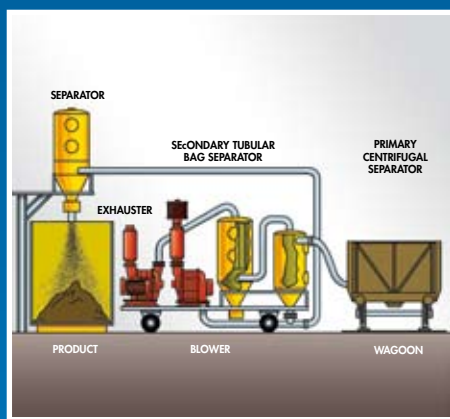

Pneumatic conveying

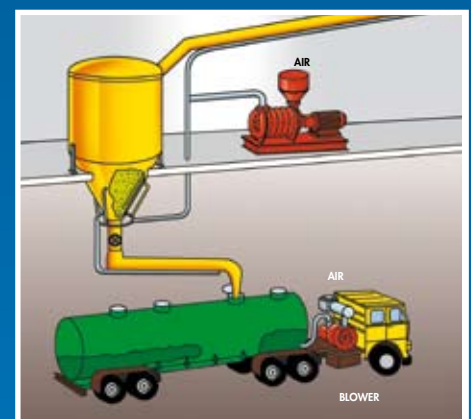

Fluidizing

VOLUME FLOW RATE/PRESSURE MAP

Pressure atm. = 1.01325 bar (14.7 PSIA) T= 20° C (68° F) RH = 36 %

BLOWER PERFORMANCE CURVES

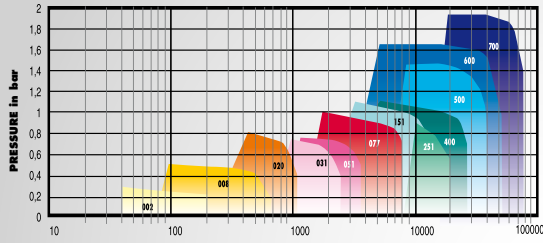

INLET AIR FLOW in m³/h

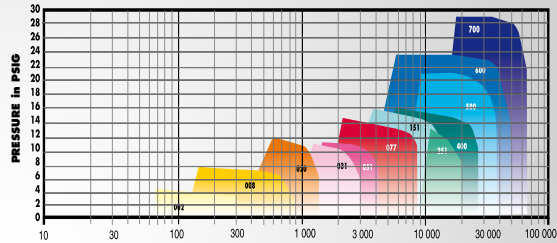

INLET AIR FLOW in CFM

EXHAUSTER PERFORMANCE CURVES

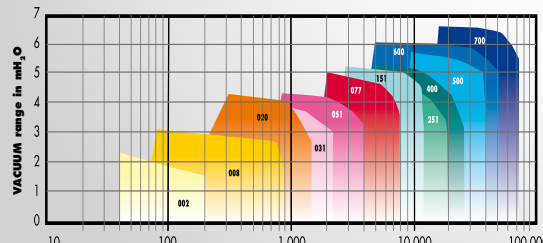

INLET AIR FLOW in m³/h

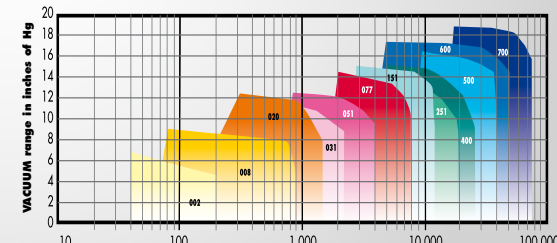

INLET AIR FLOW in CFM

CENTRIGUGAL MACHINES : TYPICAL PERFORMANCE CURVES

BLOWER

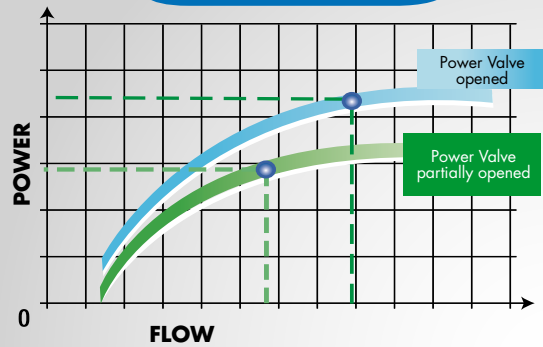

EXHAUSTER

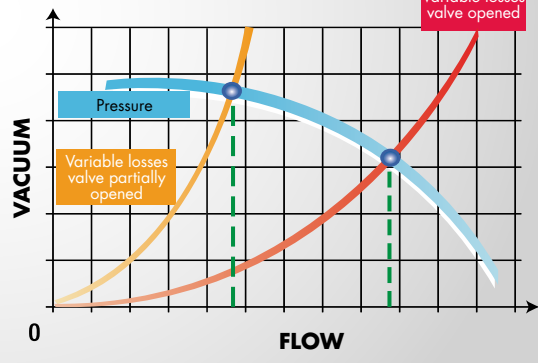
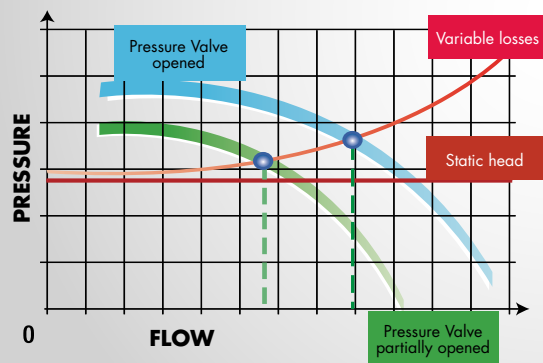
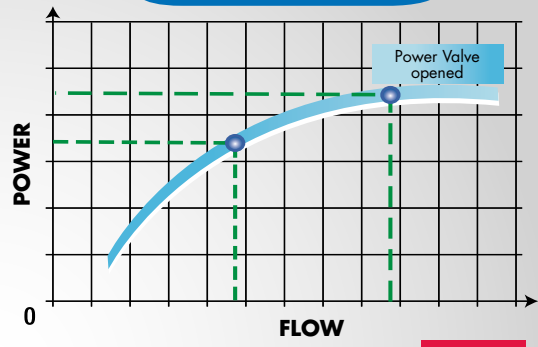

● DESIGN POINT

CONTINENTAL INDUSTRIE blowers and exhausters flow can be adjusted by inlet throttling or speed variation

FEATURES AND PERFORMANCE

BLOWER

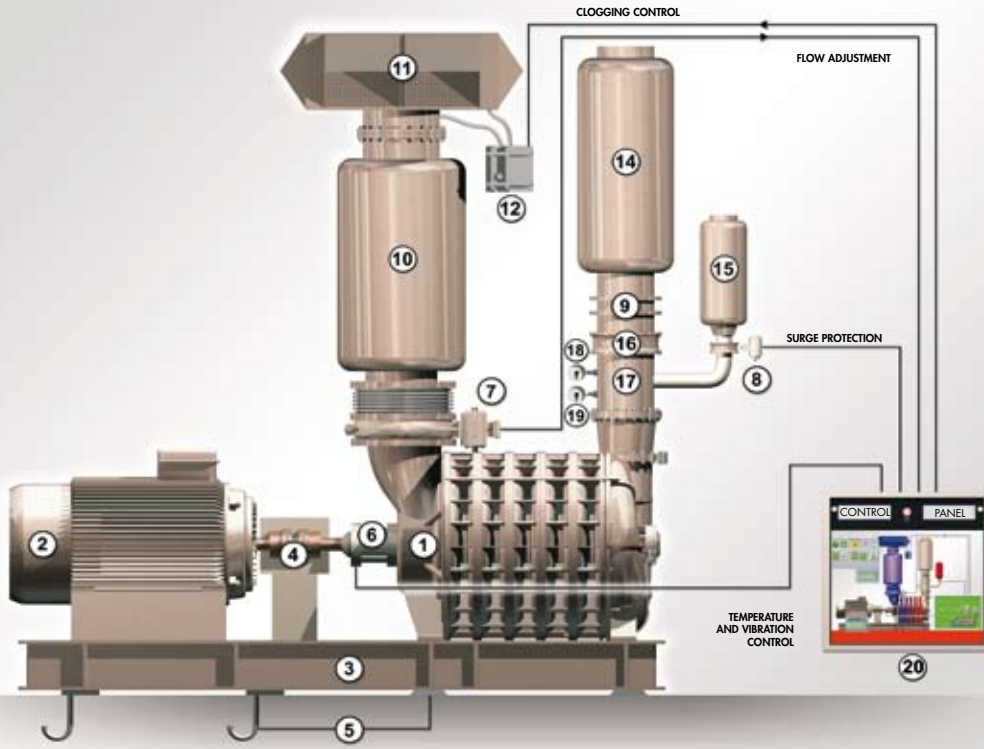

EXHAUSTER

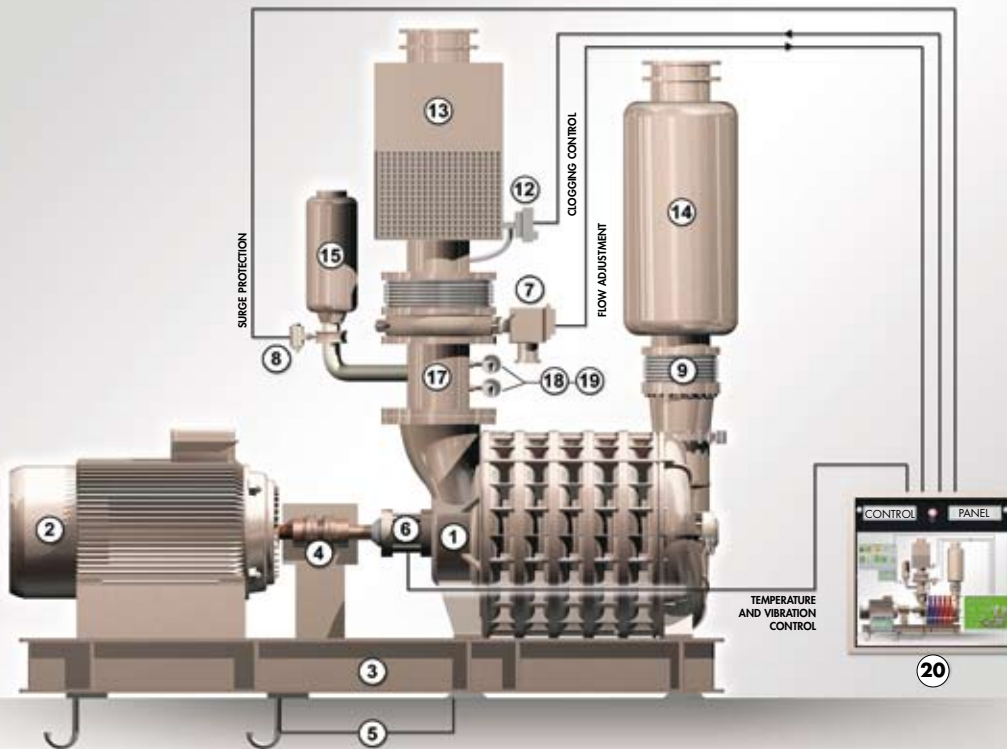

| ITEM | DESCRIPTION | ITEM | DESCRIPTION | ITEM | DESCRIPTION |
|------|--|------|---|------|-------------------|
| 1 | BLOWER or EXHAUSTER | 8 | SAFETY VALVE (pneumatic, electric or mechanical) | 15 | BLOW-OFF SILENCER |
| 2 | MOTOR | 9 | FLANGED ADAPTER with rubber sleeve or expansion joint | 16 | CHECK VALVE |
| 3 | BASE | 10 | INLET SILENCER | 17 | TEE |
| 4 | TRANSMISSION : flexible coupling, V-belt, Gear box | 11 | FILTER or FILTER-SILENCER | 18 | PRESSURE GAUGE |
| 5 | FOUNDATION PADS : resilient pads, anchor bolts | 12 | FILTER CLOGGING INDICATOR | 19 | THERMOMETER |
| 6 | TEMPERATURE PROBE & VIBRATION | 13 | INTAKE SAFETY FILTER | 20 | CONTROL PANEL |
| 7 | VALVE (manual, pneumatic or electric) | 14 | OUTLET SILENCER | | |

TESTS

ASME PTC 10 TEST

Three years of research in association with the National Sciences Institute of Lyon enabled us to develop a fix test laboratory meeting the latest ASME PTC 10 standards requirements. In this ultra-modern laboratory located over more than 1000 sqm, the information gathered are interpreted and optimized by a computerized data bank specially designed. The various parameters : air flow, pressure, air speed, sound level, temperature, vibrations amplitude and propagation, surge are direct dealt by computer. These parameters evaluate the spontaneous performances of the equipments and actualize the real working site conditions. The use of certified motors enable us to issue accurate certificates to our customers and upon request, the performance curves of their machine.

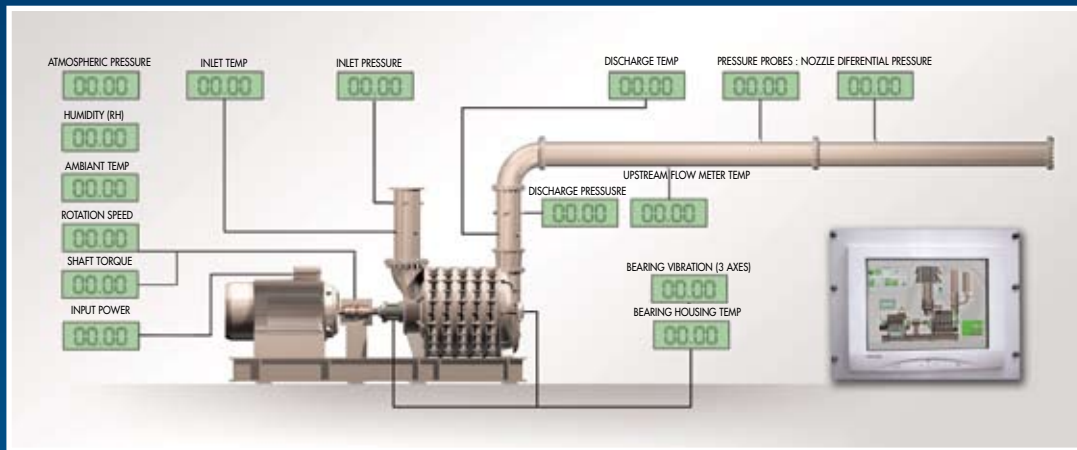

MECHANICAL TEST

All our equipments are submitted to a standard 8 hours rotational mechanical test in order to detect any housing heating, vibrations or anomaly before shipment.

CERTIFICATES

Upon request our engineers can produce all additional test certificates such as :

- Vibration test report
- Certificate of compliance material
- Dynamic balancing report
- Hydraulic test report
- Coupling alignment report
- Impeller penetration dye test report

| | kPa | bar | atm | mH ₂ O | mmHg | inchHg | PSI |
|---------------------------------|---------|---------|---------|-------------------|-----------------|---------|---------|
| 1 kPa = | 1 | 0,01 | 0,00986 | 0,10197 | 7,50061 | 0,29528 | 0,14503 |
| 1 bar = | 100 | 1 | 0,98692 | 10,1971 | 750,061 | 29,5287 | 14,5048 |
| 1 atm = | 101,325 | 1,01325 | 1 | 10,3322 | 760 | 29,92 | 14,696 |
| 1 mH ₂ O = | 9,80665 | 0,09806 | 0,09678 | 1 | 73,5559 | 2,89578 | 1,42233 |
| 1 mmHg = | 0,13332 | 0,00133 | 0,00131 | 0,01359 | 1 | 0,03936 | 0,01933 |
| 1 inchHg = | 3,38653 | 0,03386 | 0,03342 | 0,34533 | 25,4 | 1 | 0,49117 |
| 1 PSI = | 6,89473 | 0,06894 | 0,06804 | 0,70306 | 51,7147 | 2,03592 | 1 |
| CFM x 1,699 = M ³ /h | | | | | KW x 1,341 = HP | | |
| M ³ /h x 0,588 = CFM | | | | | HP x 0,745 = KW | | |



| | |
|--------------------|--|
| DEG. F | (9/5 x C°) + 32 |
| DEG. C | 5/9 (F° - 32) |
| Nm ³ /h | Measured at specific inlet conditions of 1.01325 bar (14.7 psia), 0° C (32°F), and 0% R.H. only |
| m ³ /h | Measured at specified inlet conditions |
| SCFM | Measured at specific inlet conditions of 14.7 psia (1.01325 bar), 68° F (20°C), and 36% R.H. only |
| ICFM | Measured at specified inlet conditions |



Certification ISO 9001 V 2000
July 2005



Atex Directive Category 3G
(Zone 2 and Zone 1)

AN EFFICIENT PRODUCTION FACILITY



AN EFFICIENT PRODUCTION FACILITY

As a result for our constant concern to improve our performance and by investing a large part of our resources in research, we have adapted and modernized our plant to meet a wider variety of demands. Our machining area is now operated by computerized digital control.

GREATER FLEXIBILITY

Thanks to this modernization, we have better control over production, and can now ensure our customers even greater flexibility and even shorter delivery times. In addition, spare parts and accessories can be dispatched within 24 hours.

SPECIAL APPLICATIONS

Whatever your problem of air or toxic gas you can rely on our experience :

- . Casing sealed by vacuum impregnation using "loctite",
- . Chemical treatment with nickel, HALLAR or Teflon,
- . Stainless steel impellers and shafts,
- . Sealing ensured by double carbon rings or, in extreme cases, double mechanical seals,
- . Protection of the blower body by an explosion proof housing,
- . Non sparking drive guard (aluminium),...

These are some options enabling us to respond safely to your problem

WORLD WIDE ACTIVITY

With more than 80% of its turnover from exports, and the creation of subsidiaries and branches throughout the world, CONTINENTAL INDUSTRIE understands how to increase the reputation of its products abroad. Whatever the final destination of the product, our export service has only one objective : to help you completing your project successfully.

Make CONTINENTAL INDUSTRIE your next partner for your projects of air or gas movement.



www.continental-industrie.com



CONTINENTAL INDUSTRIE S.A.S
MANUFACTURER